



TRIPLE OUTPUT POWER SUPPLIES (case sizes GT5, GT6, GT9, GT13)

INSTALLATION AND OPERATION

Threaded holes on the bottom and one side surface may be used for mounting, or the supply may be rear mounted using the same holes that attach the rear cover plate. An accessory Mounting Kit (model GB8) is available to enable mounting the power supply when the opposite side of the mounting surface is inaccessible.

Even a relatively small amount of air flowing around and through a power supply will significantly reduce the rise in its temperature resulting from operation, and therefore the temperature of the critical components within it, improving both reliability and stability. Avoid blocking air flow through vented surfaces. If the perforated bottom of a supply is mounted to a solid surface, use spacers at least 3/16" thick between it and the surface to which it is fastened, to permit convection air flow, or punch ventilation holes in the mounting surface. Allow free air to circulate around heat sinks. Space at least one inch away from surrounding objects.

Make all connections before applying AC input power.

If there is any possibility of voltage from another source (another power supply, a battery, transients, etc) being applied to the power supply's output terminals, protect the power supply by using a diode in series with one of the output leads.

Do not attempt to directly parallel the outputs of two power supplies. This would result in current flowing from the higher-set output into the lower-set output, and probable damage to both circuits. Outputs may be connected in series to obtain a higher voltage provided that a reverse-biased diode, having PIV and current ratings exceeding the combined output, is used across each output; however, keep in mind that the output current to be drawn cannot exceed the output current rating of the lowest rated supply used.

Frequent fuse failure is symptomatic of power supply overload, a short circuited output, a tripped overvoltage protector, or power supply failure. Do not overfuse; this can result in damage to the power supply.

If the AC input power contains large voltage spikes ('noise') induced by the switching of high currents, inductive loads, electro-mechanical components, etc., the input power leads to the supply should include some means of transient suppression. Otherwise, a portion of the noise may be coupled through the supply to the load. Also, the supply could be damaged. The means of suppression that is easiest to install is a 1 mfd capacitor or a metal oxide surge suppressor (MOV) across the AC input terminals of the supply. In extremely severe cases, the use of RF chokes in series with each side of the line may also be required.

These power supplies operate as constant voltage sources when used at load current equal to or less than their ratings. If the power supply is overloaded, the current limit circuit will automatically reduce the output voltage, and it will then attempt to recover to its normal operating point. Therefore, A TRANSIENT OVERLOAD RESULTS IN A MOMENTARY DROP IN OUTPUT VOLTAGE. However, if the overload is still present when the voltage attempts to recover, the voltage will continue to alternately drop and recover, which will appear as a sawtooth oscillation of the output. Do not operate the power supply in this mode; reduce the load so that an output current equal to or less than the rating of the supply will be drawn.

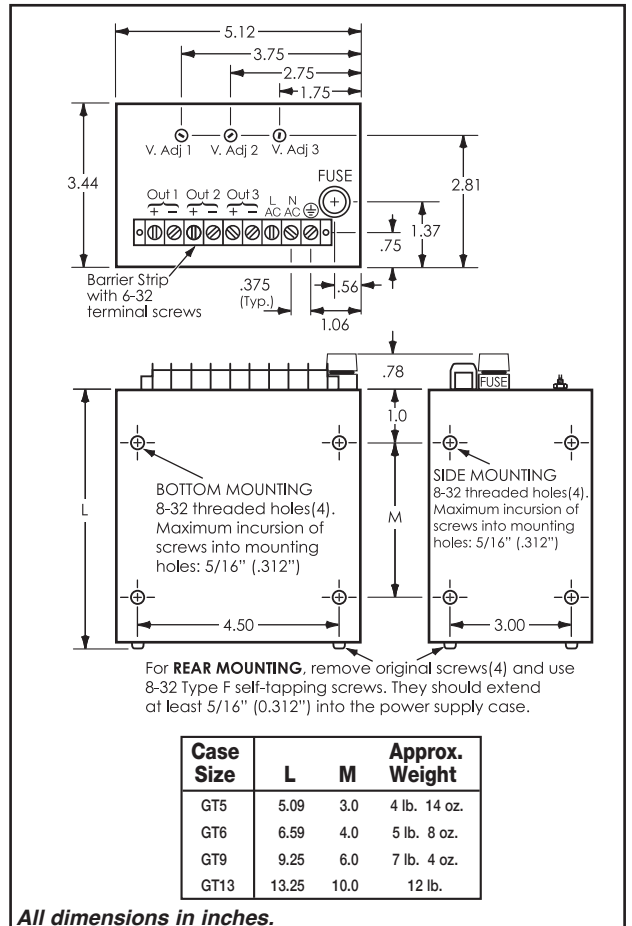

Applies to CE -certified models:

CE Marked To:
 Directive 2011/65/EU (ROHS Recast)
 Directive 2006/95/EC (Low Voltage Directive)
 Regulation (EC) No 1907/2006 (REACH)

SPECIAL MEASURES AND LIMITATIONS
To maintain compliance with the Low Voltage Directive, the following special measures and limitations must be observed when the product is placed into service:

- Evaluated for use in Pollution Degree 2 environment.
- Intended for connection to Class 1, TN-S power system.
- Models with outputs of 36 volts or less are considered to have SELV outputs.
- Models with outputs greater than 36 volts are considered to have hazardous voltage outputs and should not be located in an Operator Access area in the end product.
- Models with output ratings less than 240VA are considered to have non-hazardous energy levels. Models with output ratings of 240VA or greater are considered to have hazardous energy levels.
- Models without a built-in fuse require an external fuse to be used in the ungrounded (hot) side of the AC line.
- See catalog for electrical and mechanical specifications.
- Ground terminal must be bonded to protective earth.
- Intended to be installed within end-use equipment.



The complete Acopian catalog is available on the Internet at www.acopian.com
 131 Loomis Street, Easton, PA 18045 • Phone: (610) 258-5441 • FAX: (610) 258-2842

**ALL ACOPIAN
POWER SUPPLIES
MADE IN U.S.A.**